

JVC

SERVICE MANUAL

COLOUR TELEVISION

BASIC CHASSIS

CG

AV-14AM

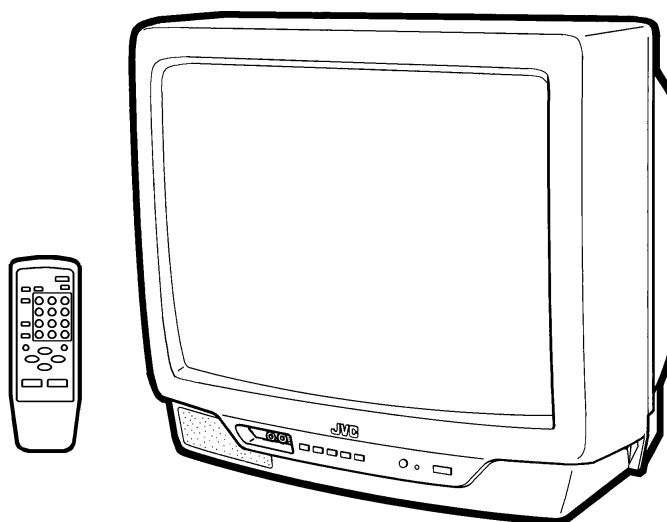

CONTENTS

- SPECIFICATIONS 2
- SAFETY PRECAUTIONS 3
- FEATURES 4
- FUNCTIONS 5
- SPECIFIC SERVICE INSTRUCTIONS 6
- SERVICE ADJUSTMENTS 12
- ★ STANDARD CIRCUIT DIAGRAM (APPENDIX) 2-1
- PARTS LIST 31

SPECIFICATIONS

ITEM		CONTENT
Dimensions(W × H × D)		364mm × 340.5mm × 375mm
Mass		9.9kg
TV RF System		B / G, I, D / K1, M
Colour System	RF Mode	PAL / SECAM / NTSC3.58 / NTSC4.43
	VIDEO Mode	PAL / SECAM / NTSC3.58 / NTSC4.43
Picture Tube		Visible size : 34cm measured diagonally
High Voltage		22.5kV ± 1.5kV(at zero beam current)
Receiving Frequency	VHF (VL)	46.25MHz ~ 168.25MHz
	VHF (VH)	175.25MHz ~ 463.25MHz
	UHF	471.25MHz ~ 863.25MHz
	CATV	Cable TVs of Mid (X-Z, S1-S10) Super (S11-S20) & Hyper (S21-S41) bands receivable
Intermediate Frequency	VIF Carrier	38.0MHz
	SIF Carrier	32.5MHz(5.5MHz), 33.5MHz(4.5MHz) 31.5MHz (6.5MHz) 32.0MHz (6.0MHz)
Colour Sub Carrier Frequency		PAL (4.43MHz), SECAM (4.40625MHz / 4.25MHz) NTSC (3.58MHz / 4.43MHz)
Power Input		AC110 ~ 240V, 50 / 60Hz
Power Consumption		70W (Max.) / 47W (Avg.)
Speaker		8cm Round type × 1
Audio Output		3W (monaural)
Aerial Input Terminal		75 Ω Unbalanced
Input (Front / Rear, Bridged connection)	Video	1V(p-p), 75 Ω, RCA × 2 (Front / Rear)
	Audio	500mV(rms) (-4dBs), High impedance, RCA × 2 (Front / Rear)
Output	Video	1V(p-p), 75 Ω, RCA × 1
	Audio	500mV(rms) (-4dBs), Low impedance, RCA × 1
Remote Control Unit		RM-C360-1H(Battery size : AA / R06 / UM-3 × 2)
Headphone jack		3.5mm stereo mini jack(Sound is monaural)

Design & specifications are subject to change without notice.

SAFETY PRECAUTIONS

- The design of this product contains special hardware, many circuits and components specially for safety purposes. For continued protection, no changes should be made to the original design unless authorized in writing by the manufacturer. Replacement parts must be identical to those used in the original circuits. Service should be performed by qualified personnel only.
- Alterations of the design or circuitry of the products should not be made. Any design alterations or additions will void the manufacturer's warranty and will further relieve the manufacturer of responsibility for personal injury or property damage resulting therefrom.
- Many electrical and mechanical parts in the products have special safety-related characteristics. These characteristics are often not evident from visual inspection nor can the protection afforded by them necessarily be obtained by using replacement components rated for higher voltage, wattage, etc. Replacement parts which have these special safety characteristics are identified in the parts list of Service manual. **Electrical components having such features are identified by shading on the schematics and by (Δ) on the parts list in Service manual.** The use of a substitute replacement which does not have the same safety characteristics as the recommended replacement part shown in the parts list of Service manual may cause shock, fire, or other hazards.
- Don't short between the LIVE side ground and ISOLATED (NEUTRAL) side ground or EARTH side ground when repairing.**
Some model's power circuit is partly different in the GND. The difference of the GND is shown by the LIVE : (\perp) side GND, the ISOLATED(NEUTRAL) : (\swarrow) side GND and EARTH : (\oplus) side GND. Don't short between the LIVE side GND and ISOLATED(NEUTRAL) side GND or EARTH side GND and never measure with a measuring apparatus (oscilloscope etc.) the LIVE side GND and ISOLATED(NEUTRAL) side GND or EARTH side GND at the same time.
If above note will not be kept, a fuse or any parts will be broken.
- If any repair has been made to the chassis, it is recommended that the B1 setting should be checked or adjusted (See ADJUSTMENT OF B1 POWER SUPPLY).
- The high voltage applied to the picture tube must conform with that specified in Service manual. Excessive high voltage can cause an increase in X-Ray emission, arcing and possible component damage, therefore operation under excessive high voltage conditions should be kept to a minimum, or should be prevented. If severe arcing occurs, remove the AC power immediately and determine the cause by visual inspection (incorrect installation, cracked or melted high voltage harness, poor soldering, etc.). To maintain the proper minimum level of soft X-Ray emission, components in the high voltage circuitry including the picture tube must be the exact replacements or alternatives approved by the manufacturer of the complete product.
- Do not check high voltage by drawing an arc. Use a high voltage meter or a high voltage probe with a VTVM. Discharge the picture tube before attempting meter connection, by connecting a clip lead to the ground frame and connecting the other end of the lead through a 10k Ω 2W resistor to the anode button.
- When service is required, observe the original lead dress. Extra precaution should be given to assure correct lead dress in the high voltage circuit area. Where a short circuit has occurred, those components that indicate evidence of overheating should be replaced. Always use the manufacturer's replacement components.

9. Isolation Check

(Safety for Electrical Shock Hazard)

After re-assembling the product, always perform an isolation check on the exposed metal parts of the cabinet (antenna terminals, video/audio input and output terminals, Control knobs, metal cabinet, screwheads, earphone jack, control shafts, etc.) to be sure the product is safe to operate without danger of electrical shock.

(1) Dielectric Strength Test

The isolation between the AC primary circuit and all metal parts exposed to the user, particularly any exposed metal part having a return path to the chassis should withstand a voltage of 3000V AC (r.m.s.) for a period of one second.

(. . . . Withstand a voltage of 1100V AC (r.m.s.) to an appliance rated up to 120V, and 3000V AC (r.m.s.) to an appliance rated 200V or more, for a period of one second.)

This method of test requires a test equipment not generally found in the service trade.

(2) Leakage Current Check

Plug the AC line cord directly into the AC outlet (do not use a line isolation transformer during this check.). Using a "Leakage Current Tester", measure the leakage current from each exposed metal part of the cabinet, particularly any exposed metal part having a return path to the chassis, to a known good earth ground (water pipe, etc.). Any leakage current must not exceed 0.5mA AC (r.m.s.).

However, in tropical area, this must not exceed 0.2mA AC (r.m.s.).

● Alternate Check Method

Plug the AC line cord directly into the AC outlet (do not use a line isolation transformer during this check.). Use an AC voltmeter having 1000 ohms per volt or more sensitivity in the following manner. Connect a 1500 Ω 10W resistor paralleled by a 0.15 μ F AC-type capacitor between an exposed metal part and a known good earth ground (water pipe, etc.). Measure the AC voltage across the resistor with the AC voltmeter. Move the resistor connection to each exposed metal part, particularly any exposed metal part having a return path to the chassis, and measure the AC voltage across the resistor. Now, reverse the plug in the AC outlet and repeat each measurement. Any voltage measured must not exceed 0.75V AC (r.m.s.). This corresponds to 0.5mA AC (r.m.s.).

However, in tropical area, this must not exceed 0.3V AC (r.m.s.). This corresponds to 0.2mA AC (r.m.s.).

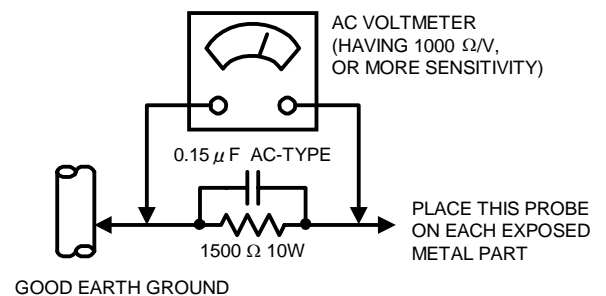

FEATURES

- New chassis design enables use of an interactive on-screen control.
- Wide range voltage (110V~240V) AC power input.
- With AUDIO / VIDEO INPUT & OUTPUT terminal.
- MUTING button can reduce the audio level to zero instantly.
- Functional remote control to operate TV set (for channel select, volume control, power ON/OFF, etc.) from a distance.
- I²C bus control utilizes single chip ICs for IF, V/C, DEF. VSM PRESET, PRESET & TURBO TIMER.
- By means of AUTO PROGRAM, the TV stations can be selected automatically and the TV channels can also be rearranged automatically.
- Built - in ON TIMER, RETURN + & CHILD LOCK.

SYSTEM BLOCK DIAGRAM

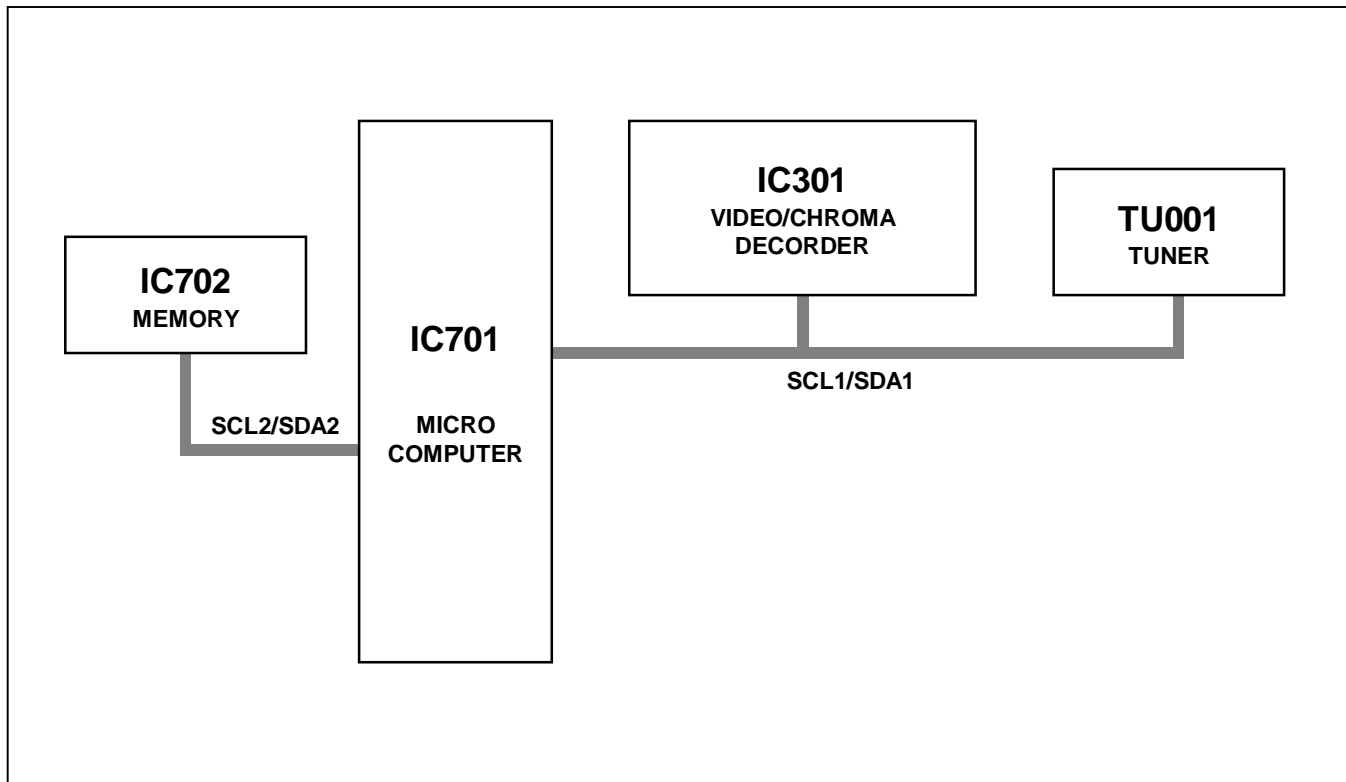

FUNCTIONS

FRONT PANEL

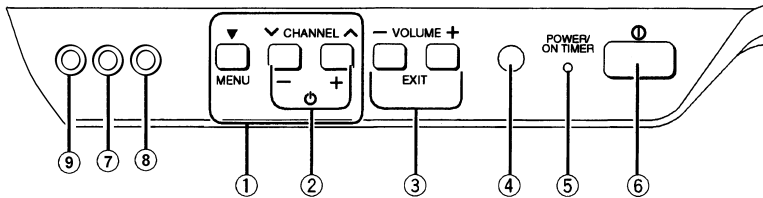

- ① MENU buttons
 - MENU button
- ② CHANNEL ∇/Δ buttons
 - MENU $-/+$ buttons
- ③ VOLUME $-/+$ buttons
- ④ Remote control sensor
- ⑤ ON TIMER / POWER lamp
- ⑥ Main power button
- ⑦ Video IN
- ⑧ Audio IN
- ⑨ Headphone Jack

REMOTE CONTROL UNIT

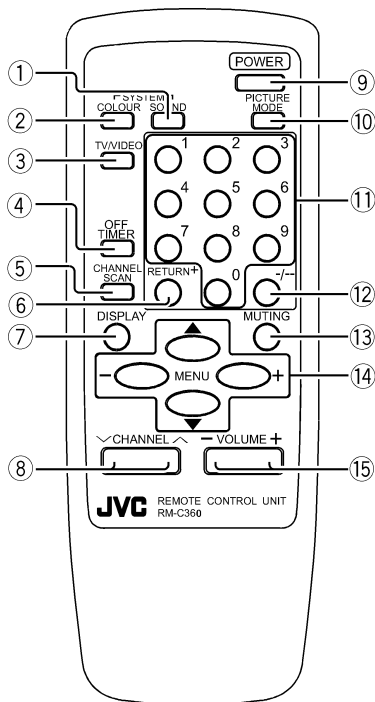

- ① SOUND SYSTEM button
- ② COLOUR SYSTEM button
- ③ TV/VIDEO button
- ④ OFF TIMER button
- ⑤ CHANNEL SCAN button
- ⑥ RETURN + button
- ⑦ DISPLAY button
- ⑧ CHANNEL ∇/Δ buttons
- ⑨ POWER button
- ⑩ PICTURE MODE button
- ⑪ Number buttons
- ⑫ $-/--$ button
- ⑬ MUTING button
- ⑭ MENU buttons
 - MENU Δ/∇ buttons
 - MENU $-/+$ buttons
- ⑮ VOLUME $-/+$ buttons

REAR PANEL

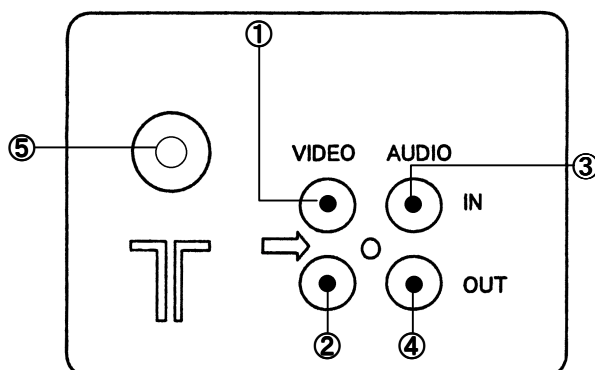

- ① VIDEO INPUT
- ② VIDEO OUTPUT
- ③ AUDIO INPUT
- ④ AUDIO OUTPUT
- ⑤ AERIAL INPUT

SPECIFIC SERVICE INSTRUCTIONS

DISASSEMBLY PROCEDURE

REMOVING THE REAR COVER

1. Unplug the power plug.
2. As shown in figure, remove the **5** screws marked **(A)** and a screw marked **(B)**.
3. Withdraw the rear cover toward you.

REMOVING THE MAIN PW BOARD

- After removing the rear cover.
1. Slightly raise the both sides of the MAIN PW BOARD by hand and remove the PWB stopper marked **(C)** from the front cabinet.
 2. Withdraw the MAIN PW BOARD backward.
(If necessary, take off the wire clamp, connectors etc.)

REMOVING THE SPEAKER

- After removing the rear cover.
1. By holding up the SPEAKER HOLDER slightly and unlocking the claw (marked **(D)**). Then SPEAKER HOLDER can be removed.
 2. Then you can remove the SPEAKER.

CHECKING THE MAIN PW BOARD

1. To check the PW Board from back side.
 - 1) Pull out the MAIN PW Board. (Refer to REMOVING THE MAIN PW Board)
 - 2) Erect the PW Board vertically so that you can easily check the back side of the PW Board.

[CAUTION]

- When erecting the PW Board, be careful so that there will be no contacting with other PW Board.
- Before turning on power, make sure that the CRT earth wire and other connector are properly connected.

WIRE CLAMPING AND CABLE TYING

1. Be sure to clamp the wire.
2. Never remove the cable tie used for tying the wires together.
Should it be inadvertently removed, be sure to tie the wires with a new cable tie.

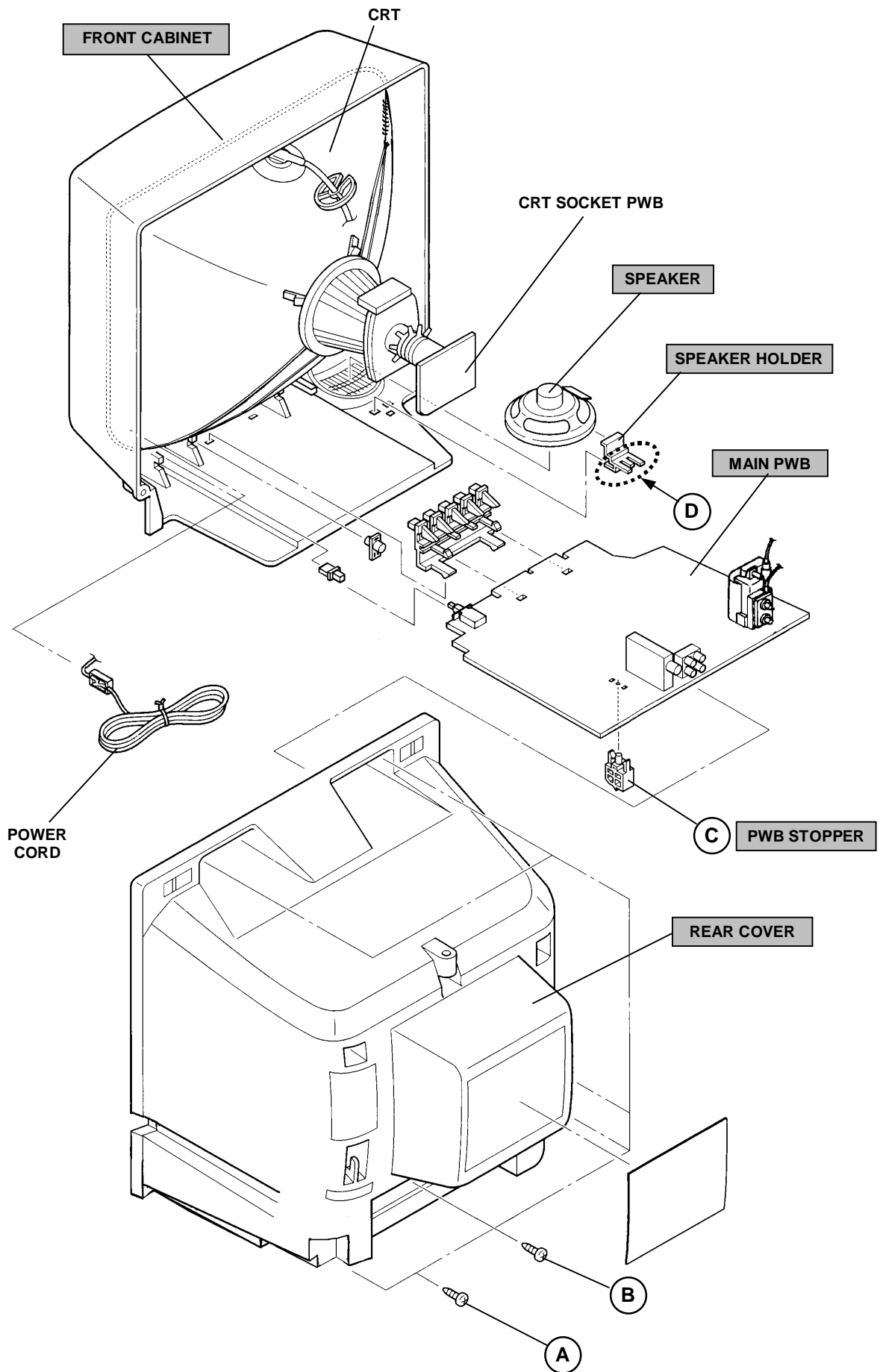

REPLACEMENT OF MEMORY ICs

1.MEMORY ICs

This model uses memory ICs. This memory IC data are for proper operation of the video and deflection circuits.
When replacing memory ICs, be sure to use ICs written with the initial values of data.

2.PROCEDURE FOR REPLACING MEMORY ICs

- (1) **Power off**
Switch the power off and disconnect the power plug from the wall outlet.
- (2) **Replace ICs**
Be sure to use memory ICs written with the initial data values.
- (3) **Power on**
Connect the power plug into the wall outlet and switch the power on.
- (4) **Check and set SYSTEM CONSTANT SET**
It must not adjust without adjustment signals.
 - 1) Press the **DISPLAY** key and the **PICTURE MODE** key of the REMOTE CONTROL UNIT simultaneously.
 - 2) The SERVICE MENU screen of Fig. 1 will be displayed.
 - 3) While the SERVICE MENU is displayed, again press the **DISPLAY** key and **PICTURE MODE** key simultaneously, and the SYSTEM CONSTANT SET screen of Fig. 2 will be displayed.
 - 4) Check the setting values of the SYSTEM CONSTANT SET of Table 1. If the value is different, select the setting item with the **MENU ▼/▲** key, and set the correct value with the **MENU - / +** key.
 - 5) Press the **DISPLAY** key twice, and return to the normal screen.
- (5) **Receive channel of setting**
Refer to the **OPERATING INSTRUCTIONS** and set the receive channels (channels preset) as described
- (6) **User Setting**
Check the user setting value of Table 2, and if setting value is different, set the correct value.
For setting, refer to the **OPERATING INSTRUCTIONS**.
- (7) **Setting of SERVICE MENU**
Verify the setting items of the SERVICE MENU of Table 3, and reset where necessary.
For setting, refer to the **SERVICE ADJUSTMENTS**.

Key assignment of remote control unit

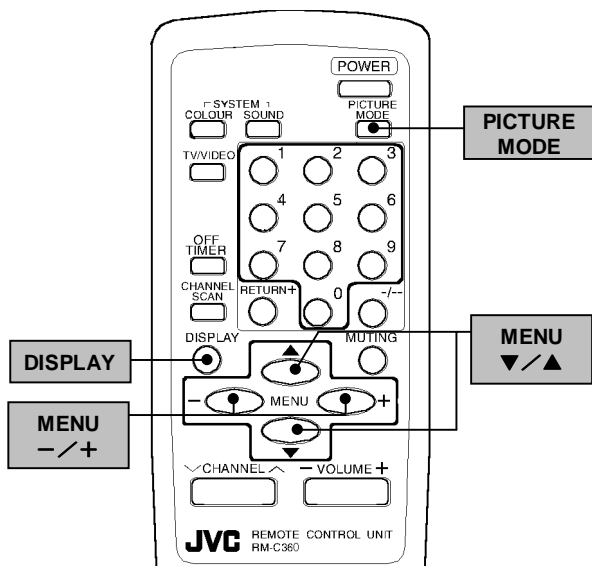

SERVICE MENU

SERVICE MENU	
1.IF	2.V/C
3.DEF	4.VSM PRESET
5.PRESET	
6.TURBO TIMER OFF	
1-6 SELECT	DISP : EXIT
*****	**.**
*** **	*** **

Fig.1

SYSTEM CONSTANT- I

SYSTEM CONSTANT SET 1	
COLOUR	: MULTI
BILINGUAL	: NO
TUNER	: MU
ECO SENSOR	: NO
LANGUAGE	: E/R/A/F
▼/▲: SELECT	
-/+ : OPERATE	DISP : EXIT

SYSTEM CONSTANT- II

SYSTEM CONSTANT SET 2	
B/B SOUND	: OFF
LOCK	: 180
COLOUR AUTO	: NO
QSS	: MINT
ALC	: NO
TEXT RATE	: 20
▼▲:SEL	- + :OPE DISP:EXIT

SYSTEM CONSTANT- III

SYSTEM CONSTANT SET 3	
AMP TUNER	: NO
▼▲:SEL	- + :OPE DISP:EXIT

Fig.2

SETTING OF SYSTEM CONSTANT SET

Setting item	Setting contents	Setting value
COLOUR	<input type="radio"/> MULTI <input type="radio"/> TRIPLE <input checked="" type="radio"/> PAL <input type="radio"/>	MULTI
BILINGUAL	<input type="radio"/> YES <input checked="" type="radio"/> NO <input type="radio"/>	NO
TUNER	<input type="radio"/> MU <input checked="" type="radio"/> MA <input type="radio"/>	MU
ECO SENSOR	<input type="radio"/> YES <input checked="" type="radio"/> NO <input type="radio"/>	NO
LANGUAGE	<input type="radio"/> E/R/A/F <input checked="" type="radio"/> E/A/F <input type="radio"/> E/A <input type="radio"/> E/F <input type="radio"/>	E/R/A/F
B/B SOUND	<input type="radio"/> ON <input checked="" type="radio"/> OFF <input type="radio"/>	OFF
LOCK	YES ↔ 10 ↔ 20 ↔ ~ ↔ 230 ↔ 240 ↔ 250	180
COLOUR AUTO	<input type="radio"/> YES <input checked="" type="radio"/> NO <input type="radio"/>	NO
QSS	<input type="radio"/> MINT <input checked="" type="radio"/> MQSS <input type="radio"/>	MINT
ALC	<input type="radio"/> YES <input checked="" type="radio"/> NO <input type="radio"/>	NO
TEXT RATE	10 ↔ 20 ↔ 40 ↔ 80	20
AMP TUNER	<input type="radio"/> YES <input checked="" type="radio"/> NO <input type="radio"/>	NO

Table 1

USER SETTING VALUES

Setting item	Setting value	Setting item	Setting value
1. Setting of FUNCTIONS		2. Setting of MENU	
MAIN POWER	OFF	ON TIMER	PR1 0:00
SUB POWER	ON	VNR	OFF
CHANNEL POSITION	1 POSITION	AUTO SHUTOFF	OFF
VOLUME	Appropriate sound volume	CHILD LOCK	OFF
TV/VIDEO(INPUT)	TV	BLUE BACK	OFF
ON SCREEN DISPLAY	POSITION NUMBER DISPLAY	CHANNEL PRESET	Refer to OPERATING INSTRUCTION
COLOUR SYSTEM	AUTO PAL	LANGUAGE	ENGLISH
SOUND SYSTEM	B / G	TINT	Refer to VSM PRESET
OFF TIMER	OFF	COLOUR	Refer to VSM PRESET
PICTURE MODE (VSM)	BRIGHT	BRIGHT	Refer to VSM PRESET
		CONT.	Refer to VSM PRESET
		SHARP	Refer to VSM PRESET

Table 2

SERVICE MENU SETTING ITEMS

Service menu	Setting item	Service menu	Setting item
1. IF	1. VCO 2. DELAY POINT	5. PRESET	<div style="border: 1px dashed black; padding: 5px;"> 1. C-TRAP FIX 2. SHARP PEAK 3. ABL 4. GAMMA 5. Y DELAY TIME 6. BLACK EXP START 7. C-BPF 8. CW/SCP 9. VIF DET LEVEL 10. SIF DET LEVEL 11. IF AGC MIN. 12. VIF AGC 13. VIF PMOD 14. SIF BPF BW ADJUST 15. SIF TRAP FO ADJUST 16. SIF TRAP FO ADJUST 2 17. SIF -TRAP 18. SIF -BPF 19. VNR 20. RGB LIM 21. RGB LIMIT LEVEL 22. SIF SW 23. TEXT H POSITION 24. READ DATA </div>
2. V/C	1. CUT OFF (R / G / B) 2. DRIVE (R / B) 3. BRIGHT 4. CONT. 5. COLOUR (P / S / N3 / N4) 6. TINT (N3 / N4) 7. SECAM BL ADJUST 8. SHARP (TV/VIDEO) ← <div style="border: 1px solid black; padding: 2px; width: fit-content; margin-left: auto; margin-right: auto;">DO NOT ADJUST</div>		
3. DEF	1. VER. POSITION 2. HOR. POSITION 3. VER. HEIGHT 4. VER. LINEARITY 5. VER. SCURVE 6. HOR. VCO ADJUST ← <div style="border: 1px solid black; padding: 2px; width: fit-content; margin-left: auto; margin-right: auto;">DO NOT ADJUST</div>		
4. VSM PRESET (BRIGHT/STD/SOFT)	TINT COLOUR BRIGHT CONT. SHARP	6. TURBO TIMER	ON or OFF (Should be OFF) If it is ON, the timer in TIMER mode changes from 1 minute into 1 sec temporarily. (It is easier to checks the Operation of TIMER) If you turn the TV power off, this setting becomes OFF automatically.

Table 3

REPLACEMENT OF IC301 (IF VIDEO/CHROMA DECODER)

For the IC301 (IF Video/Chroma Decoder) of this model, all data are written in the micro-computer. So, write the data in the micro-computer in accordance with the following procedures before starting adjustment.

REPLACING PROCEDURES

- (1) Turn the POWER OFF.
- (2) Replace the IC301 with a new one.
- (3) While pressing **MENU** button and **VOL+** button ON the FRONT CABINET simultaneously, turn the POWER ON. When the POWER is turned ON, the data is written in the micro computer immediately.

FRONT CABINET

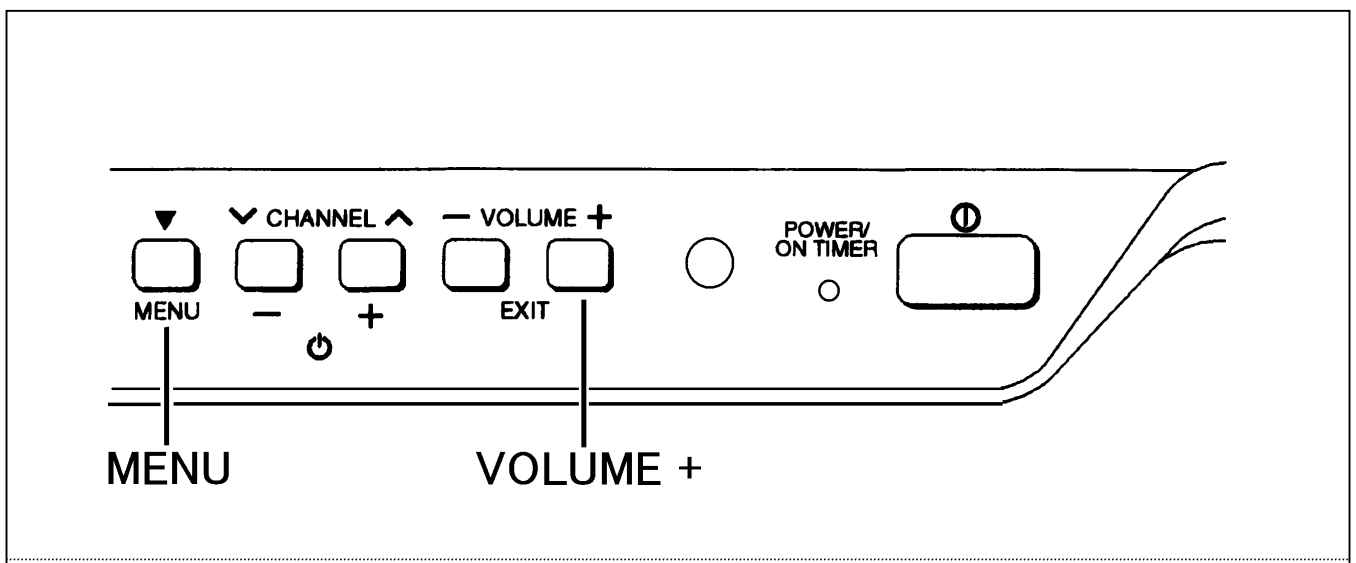

SERVICE ADJUSTMENTS

BEFORE STARTING SERVICE ADJUSTMENT

1. There are 2 way of adjusting this TV: One is with the REMOTE CONTROL UNIT and the other is the conventional method using adjustment parts and components.
2. The setting (adjustment) using the REMOTE CONTROL UNIT is made on the basis of the initial setting values. The setting values which adjust the screen to the optimum condition can be different from the initial setting values.
3. Make sure that connection is correctly made to AC power source.
4. Turn on the power of the TV and measuring equipment for warming up for at least 30 minutes before starting adjustment.
5. If the receive or input signal is not specified, use the most appropriate signal for adjustment.

6. Never touch parts (such as variable resistors, transformers and condensers) not shown in the adjustment items of this service adjustment.
7. Preparation for adjustment (presetting):
Unless otherwise specified in the adjustment items, preset the following functions with the REMOTE CONTROL UNIT.

PICTURE MODE (VSM)	BRIGHT
TINT / COLOUR / BRIGHT / CONT / SHARP	Refer to VSM
VNR	OFF
BLUE BACK	OFF
AUTO SHUT OFF	OFF

MEASUREMENT INSTRUMENT

AND FIXTURES

1. DC voltmeter (or digital voltmeter)
2. Oscilloscope
3. Signal generator (Pattern generator) [PAL / SECAM / NTSC]
4. Remote control unit

ADJUSTMENT ITEMS

Adjustment item	Adjustment item
B1 POWER SUPPLY	DEFLECTION circuit adjustment
FOCUS adjustment	VSM PRESET adjustment
IF circuit adjustment	PRESET adjustment
VIDEO/CHROMA circuit adjustment	PURITY / CONVERGENCE Adjustment

BASIC OPERATION OF SERVICE MENU

1. TOOL OF SERVICE MENU OPERATION

Operate the SERVICE MENU with the REMOTE CONTROL UNIT.

2. SERVICE MENU ITEMS

With the SERVICE MENU, various settings (adjustments) can be made, and they are broadly classified in the following items of settings :

- 1. IF For entering/adjusting the setting values (adjustment values) of the IF circuit.
- 2. V/C For entering/adjusting the setting values (adjustment values) of the VIDEO/CHROMA circuit.
- 3. DEF..... For entering / adjusting the setting values (adjustment values) of the DEFLECTION circuit.
- 4. VSM PRESET For setting the values of BRIGHT, STANDARD, and SOFT.
(VSM : video status memory)
- 5. PRESET This is used when the PRESET MODE is adjusted. **[Do not adjust]**
- 6. TURBO TIMER For quick setting the values of TIMER COUNT-adjustable not only by minutes but also by second. If it is on, the time in TIMER mode changes from 1 minute into 1 second temporarily. If you turn the TV power off, this setting becomes OFF automatically. (applicable to OFF TIMER, ON TIMER, AUTO SHUTOFF). **[Should be OFF]**

3. BASIC OPERATION OF SERVICE MENU

(1) How to enter SERVICE MENU

Press the **DISPLAY** key and the **PICTURE MODE** key of the REMOTE CONTROL UNIT simultaneously.
The SERVICE MENU screen of Fig. 1 will be displayed.

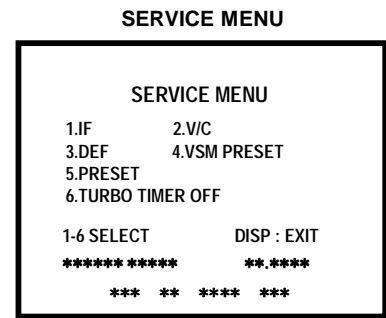

Fig.1

(2) Selection of SUB MENU SCREEN

Press one of the keys 1 ~ 6 of the REMOTE CONTROL UNIT, and select the SUB MENU SCREEN (See Fig.2 on the next page) from the SERVICE MENU.

- SERVICE MENU → SUB MENU
- 1. IF
 - 2. V / C
 - 3. DEF
 - 4. VSM PRESET
 - 5. PRESET
 - 6. TURBO TIMER

(3) Method of Setting

- * Once the setting values are set, they are memorized automatically.
- * It must not adjust without signal.

1) **1. IF**

[1. VCO]

- ① 1 Key Select **1. IF**.
- ② 1 Key Select 1. VCO(CW).
- ③ VCO(CW) Adjust VCO(CW) while watching the colour (yellow / blue) of the characters on the screen. For details, refer to the adjustment table.
- ④ DISPLAY Key When this is pressed twice, you will return to the SERVICE MENU.

[2. DELAY POINT]

- ① 1 Key Select **1. IF**.
- ② 2 Key Select 2. DELAY POINT.
- ③ MENU - / + Key Set (adjust) the setting values of the setting items.
- ④ DISPLAY Key When this is pressed twice, you will return to the SERVICE MENU.

2) **2. V/C, 3. DEF, 4.VSM PRESET and 5. PRESET**

- ① 2~5 Keys Select one from **2. V/C, 3.DEF, 4.VSM PRESET and 5. PRESET**.
- ② MENU Δ / ▽ key Select setting items.
- ③ MENU - / + Key Set (adjust) the setting values of the setting items. (Use the number keys of the REMOTE CONTROL UNIT for setting of WHITE BALANCE and BLACK OFFSET. For the setting, refer to each item concerned.)
- ④ DISPLAY Key When this is pressed , you will return to the SERVICE MENU.

3) **6. TURBO TIMER**

- ① By pressing the 6-key, you can change the ON/OFF position. **[Should be OFF]**

(4) Release of SERVICE MENU

After completing the setting, return to the SERVICE MENU by pressing the **DISPLAY** key, then again press the **DISPLAY** key to return to the normal screen.

SUB MENU SCREEN (Fig.2)

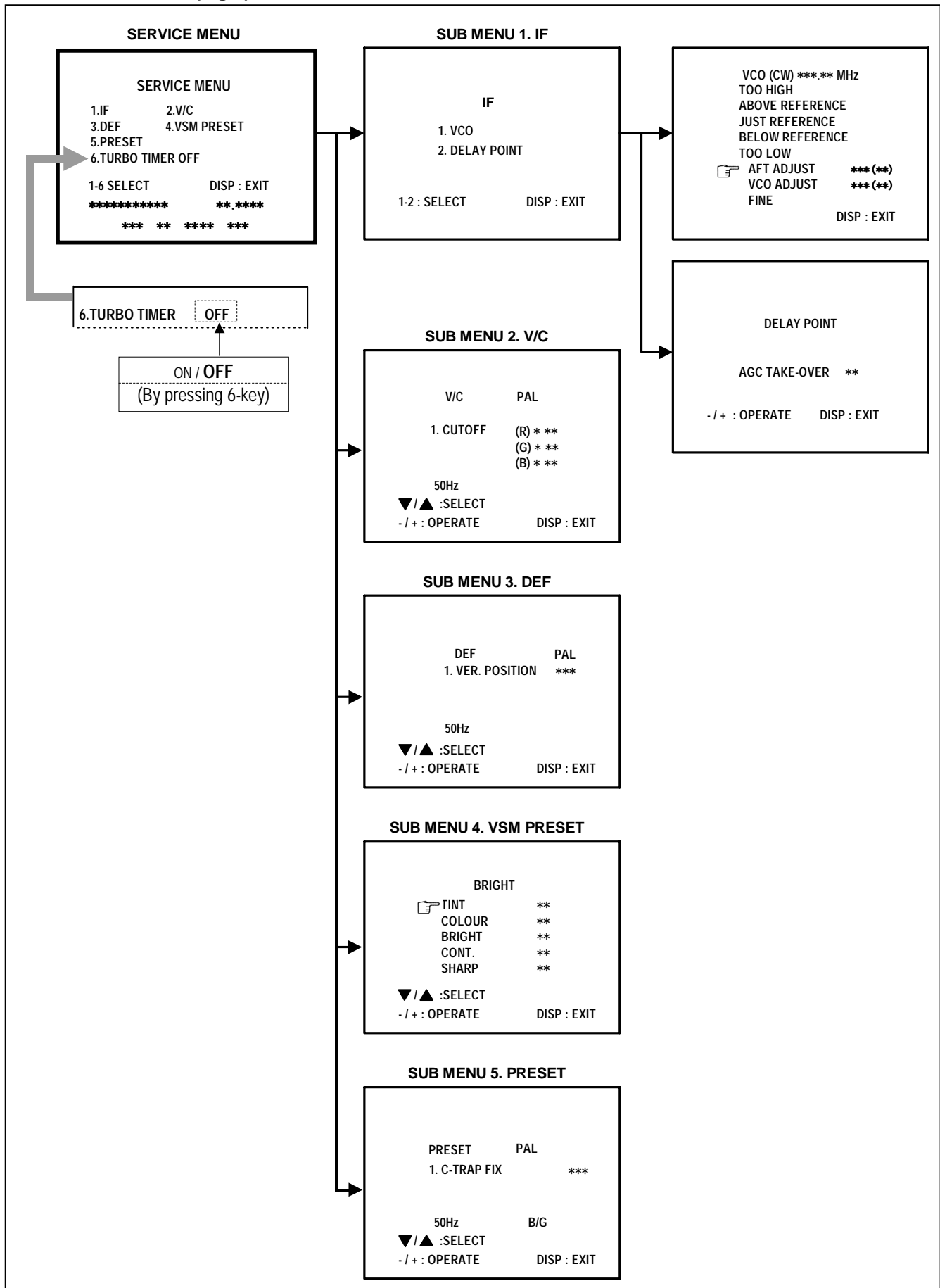

ADJUSTMENT LOCATIONS

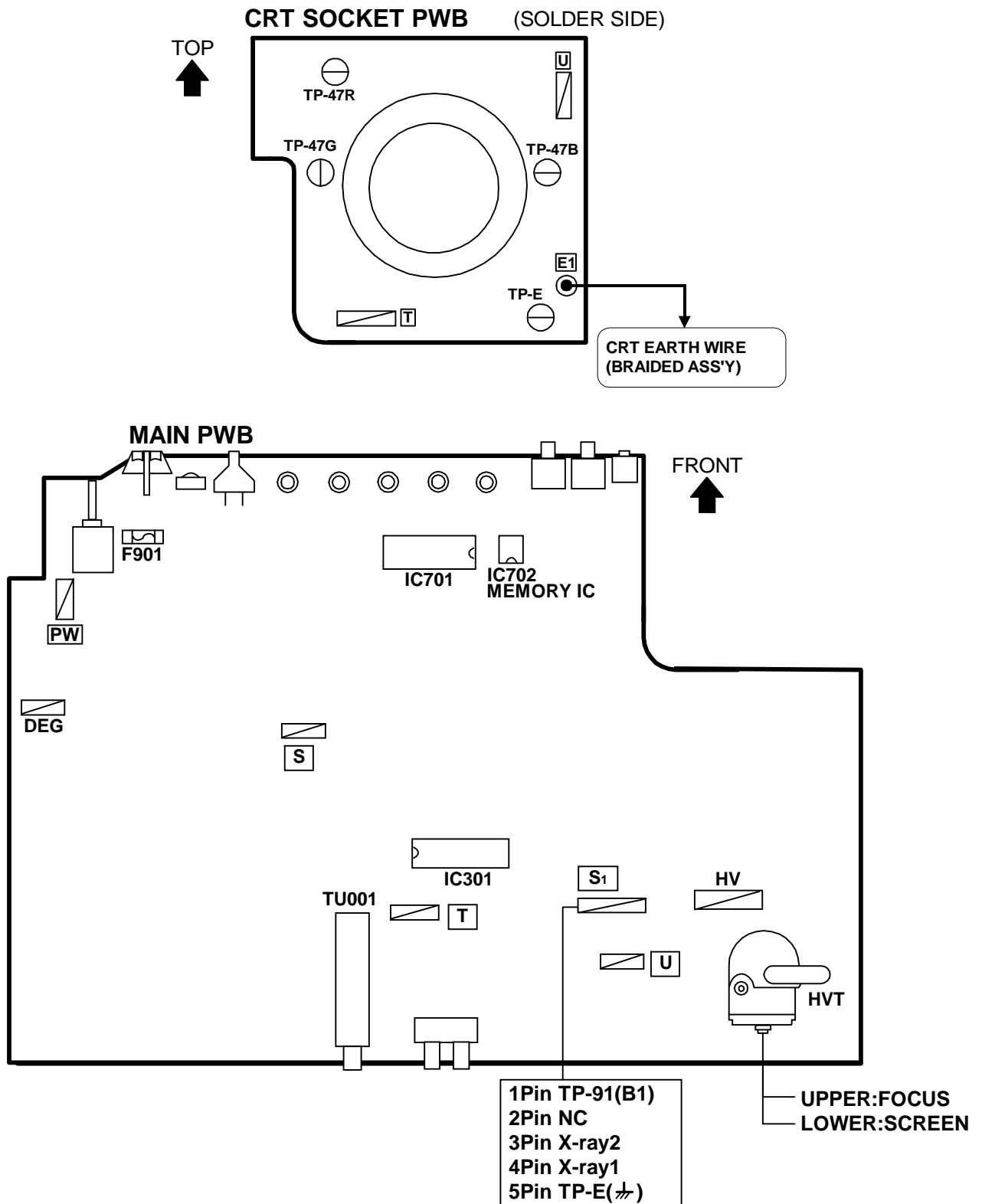

ADJUSTMENTS

B1 POWER SUPPLY

Item	Measuring instrument	Test point	Adjustment part	Description
Check of B1 Power Supply	Signal generator DC Volt-meter	TP-91 (B1) TP-E (↕)		1. Receive a whole black signal. 2. Connect a DC voltmeter to TP-91(B1) and TP-E (↕). 3. Make sure that the voltage is $DC114.5 \pm 1.5V$.

FOCUS ADJUSTMENT

Item	Measuring instrument	Test point	Adjustment part	Description
Adjustment of FOCUS	Signal generator		FOCUS VR [In HVT]	1. Receive a cross-hatch signal. 2. While watching the screen, adjust the FOCUS VR to make the vertical and horizontal lines as fine and sharp as possible. 3. Make sure that when the screen is darkened, the lines remain in good focus.

IF CIRCUIT ADJUSTMENT

Item	Measuring instrument	Test point	Adjustment part	Description
Adjustment of VCO(CW)	Signal generator Remote control unit		1. VCO	<p>● Please use signal generator which is correct proof about the sending frequency.</p> <ol style="list-style-type: none"> 1. Receive the PAL full colour bar (210.25MHz) signal. 2. Select 1.IF from the SERVICE MENU. 3. Press 1 key and select 1.VCO. 4. Select VCO ADJUST with MENU ▲/▼ key. 5. Press MENU -/+ key until the colour of the characters TOO HIGH changes blue to yellow. Then gradually press the MENU -/+ key until the TOO LOW changes yellow. At this time, confirm that the value of VCO ADJUST is near +00. 6. Select AFT ADJUST with MENU ▲/▼ key. 7. Press MENU -/+ key until the characters JUST REFERENCE changes blue to yellow. 8. Press the DISPLAY key three times to return to normal screen.

VCO (CW)***** MHz
TOO HIGH
ABOVE REFERENCE
JUST REFERENCE ← YELLOW
BELOW REFERENCE
TOO LOW
AFT ADJUST *** (**)
VIF VCO ADJUST *** (**)
FINE ← Do not adjust
DISP : EXIT

TOO HIGH
ABOVE REFERENCE
JUST REFERENCE
BELOW REFERENCE
TOO LOW
ADJUSTMENT AT THIS POINT IS USELESS
ADJUSTMENT POINT

Item	Measuring instrument	Test point	Adjustment part	Description								
Adjustment of DELAY POINT (AGC)	Signal generator Remote control unit		DELAY POINT (AGC TAKE-OVER)	1. Receive a black and white signal (colour off). 2. Select 1. IF from the SERVICE MENU. 3. Select 2. DELAY POINT by pressing the 2 key on the remote control unit. 4. Adjust the MENU - or + key until video noise disappears. 5. Turn to other channels and make sure that there are no irregularities.								
					<table border="1"> <thead> <tr> <th>DELAY POINT (AGC TAKE OVER)</th> <th>Initial setting value</th> </tr> </thead> <tbody> <tr> <td>NTSC 3.58</td> <td>48</td> </tr> <tr> <td>OTHER</td> <td>43</td> </tr> </tbody> </table>		DELAY POINT (AGC TAKE OVER)	Initial setting value	NTSC 3.58	48	OTHER	43
					DELAY POINT (AGC TAKE OVER)	Initial setting value						
					NTSC 3.58	48						
OTHER	43											

VIDEO / CHROMA CIRCUIT ADJUSTMENT

The setting (adjustment) using the REMOTE CONTROL UNIT is made on the basis of the initial setting values. The setting values which adjust the screen to the optimum condition can be different from the initial setting values. Do not change the initial setting values of the setting items not listed in "ADJUSTMENT".

Setting item		Colour system	Initial setting value			
			PAL	SECAM	NTSC 3.58	NTSC 4.43
1. CUT OFF	RED		-50			
	GREEN		-50			
	BLUE		-50			
2. DRIVE	RED		+0			
	BLUE		+0			
3. BRIGHT			+0			
4. CONT.			+0			
5. COLOUR			+0	+0	+0	+0
6. TINT	TV		—	—	+0	(+0)
	VIDEO		—	—	+8	(+0)
7. SECAM BL ADJUST			—	+0	—	—
8. SHARP (Do not adjust)	TV		-15			
	VIDEO		+5			

() : OFFSET Value

Item	Measuring instrument	Test point	Adjustment part	Description										
<p>Adjustment of WHITE BALANCE (Low light)</p>	<p>Signal generator Remote control unit</p>		<p>1. CUT OFF (R) CUT OFF (G) CUT OFF (B)</p> <p>SCREEN VR [IN HVT]</p>	<p>1. Receive a black and white signal (colour off). 2. From the SERVICE MENU, select 2. V/C to display 1. CUT OFF (R), (G) and (B) . 3. Set each value to initial setting value with 4~9 keys of the remote control unit. 4. Press the 1 key of the remote control unit to show the single horizontal line on screen. 5. Turn the SCREEN VR fully counter-clockwise, then slowly turn it clockwise to where one of a red, blue or green colour is faintly visible. 6. Use keys 4~9 of the remote control unit and adjust the other 2 colours which except the appeared colour to where the single horizontal line appears white. 7. Turn the SCREEN VR to where the single horizontal line glows faintly. 8. Press the 2 key to turn off the single horizontal line. 9. Press the DISPLAY key twice to return to the normal screen.</p> <table border="1" data-bbox="775 1003 1385 1189"> <thead> <tr> <th>Adjustment item</th> <th>Variable range</th> <th>Initial setting value</th> </tr> </thead> <tbody> <tr> <td rowspan="3">1. CUT OFF</td> <td>R</td> <td>-128~+127</td> </tr> <tr> <td>G</td> <td>-128~+127</td> </tr> <tr> <td>B</td> <td>-128~+127</td> </tr> </tbody> </table>	Adjustment item	Variable range	Initial setting value	1. CUT OFF	R	-128~+127	G	-128~+127	B	-128~+127
Adjustment item	Variable range	Initial setting value												
1. CUT OFF	R	-128~+127												
	G	-128~+127												
	B	-128~+127												
<p>Adjustment of WHITE BALANCE (High light)</p>	<p>Signal generator Remote control unit</p>		<p>2. DRIVE (R) DRIVE (B)</p>	<p>1. Receive a black and white signal (colour off). 2. Select 2. V/C from the SERVICE MENU. 3. Select 2. DRIVE (R) / (B) with MENU ▼/▲ key, and set each value to initial setting value with 4 and 7 or 6 and 9 keys of the remote control unit. 4. Use the keys 4 and 7 or 6 and 9 to produce a white screen 5. Press the DISPLAY key twice to return to the normal screen.</p> <table border="1" data-bbox="775 1771 1385 1921"> <thead> <tr> <th>Adjustment item</th> <th>Variable range</th> <th>Initial setting value</th> </tr> </thead> <tbody> <tr> <td rowspan="2">2. DRIVE</td> <td>R</td> <td>-64~+63</td> </tr> <tr> <td>B</td> <td>-64~+63</td> </tr> </tbody> </table>	Adjustment item	Variable range	Initial setting value	2. DRIVE	R	-64~+63	B	-64~+63		
Adjustment item	Variable range	Initial setting value												
2. DRIVE	R	-64~+63												
	B	-64~+63												

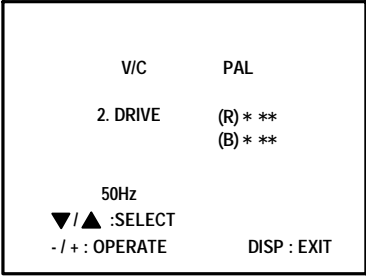
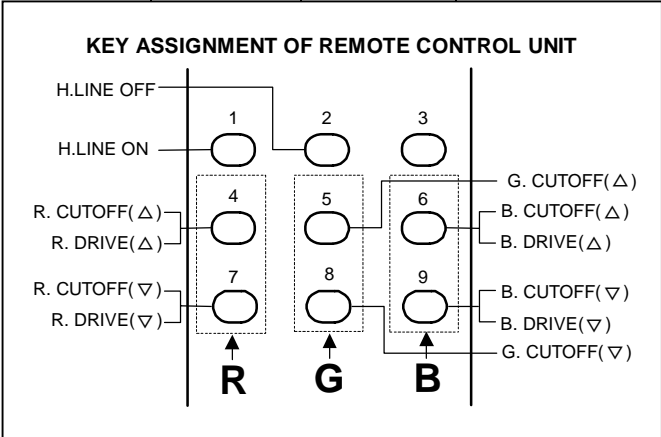
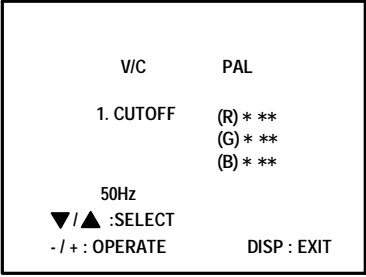

Item	Measuring instrument	Test point	Adjustment part	Description
Adjustment of SUB BRIGHT	Remote control unit		3. BRIGHT	<ol style="list-style-type: none"> 1. Receive any broadcast. 2. Select 2. V/C from SERVICE MENU. 3. Select 3. BRIGHT with the MENU ▼/▲key. 4. Set the initial setting value with the MENU - or + key. 5. If the brightness is not the best with the initial set value, make fine adjustment until you get the best brightness.
Adjustment of SUB CONT.	Remote control unit		4. CONT.	<ol style="list-style-type: none"> 1. Receive any broadcast. 2. Select 2. V/C from SERVICE MENU. 3. Select 4. CONT. with the MENU ▼/▲key. 4. Set the initial setting value with the MENU - or + key. 5. If the contrast is not the best with the initial set value, make fine adjustment until you get the best contrast.
Adjustment of SUB COLOUR I	Remote control unit		5. COLOUR	[Method of adjustment without measuring instrument]
			PAL COLOUR	<ol style="list-style-type: none"> 1. Receive a PAL broadcast. 2. Select 2. V/C from the SERVICE MENU. 3. Select 5. COLOUR with the MENU ▼/▲ key. 4. Set the initial setting value for PAL COLOUR with the MENU - or + key. 5. If the colour is not the best with the initial set value, make fine adjustment until you get the best colour.
			SECAM COLOUR	<ol style="list-style-type: none"> 1. Receive a SECAM broadcast. 2. Make fine adjustment of SECAM COLOUR as previously.
			NTSC 3.58 COLOUR	<ol style="list-style-type: none"> 1. Receive a NTSC 3.58MHz broadcast. 2. Make similar fine adjustment of NTSC 3.58 COLOUR as previously.
			NTSC 4.43 COLOUR	When NTSC 3.58 adjustment completed, NTSC 4.43 will be automatically set at the respective values.

Item	Measuring instrument	Test point	Adjustment part	Description
Adjustment of SUB COLOUR II	Signal generator Oscilloscope Remote control unit	TP-47R/G TP-E (↔) [CRT SOCKET PWB]	5. COLOUR	[Method of adjustment using measuring instrument]
			PAL COLOUR	<ol style="list-style-type: none"> 1. Receive a PAL full field colour bar signal (75% white). 2. Select 2. V/C from SERVICE MENU. 3. Select 5. COLOUR with the MENU ▼/▲ key. 4. Set the initial setting value of PAL COLOUR with the MENU - or + key. 5. Connect the oscilloscope between TP-47R/G and TP-E. 6. Adjust PAL COLOUR to bring the value of (A) in the illustration to +9V (W&G).
			SECAM COLOUR	<ol style="list-style-type: none"> 1. Receive a SECAM full field colour bar signal (75% white). 2. Set the initial setting value of SECAM COLOUR with the MENU - or + key. 3. Adjust SECAM COLOUR to bring the value of (A) in the illustration to +3V (W & G).
			NTSC 3.58 COLOUR	<ol style="list-style-type: none"> 1. Receive a NTSC 3.58 full field colour bar signal (75% white). 2. Set the initial setting value of NTSC 3.58 COLOUR with the MENU - or + key. 3. Adjust NTSC 3.58 COLOUR to bring the value of (A) in the illustration to +7V (W&G).
NTSC 4.43 COLOUR	When NTSC 3.58 is set, NTSC 4.43 will be automatically set at the respective values.			

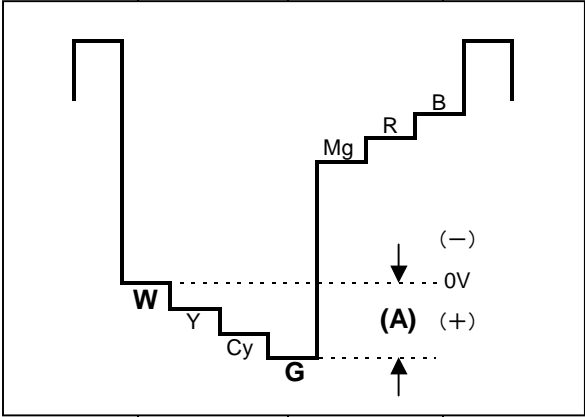

Item	Measuring instrument	Test point	Adjustment part	Description		
Adjustment of TINT I	Signal generator Remote control unit		6. TINT	[Method of adjustment without measuring instrument]		
			NTSC 3.58 TINT	<ol style="list-style-type: none"> 1. Receive a NTSC 3.58 full field colour bar signal (75% white). 2. Select 2. V/C from SERVICE MENU. 3. Select 6. TINT with the MENU ▼/▲ key. 4. Set the initial setting value of NTSC 3.58 with the MENU - or + key. 5. If you cannot get the best tint with the initial setting value, make fine adjustment until you get the best tint. 		
NTSC 4.43 TINT	When NTSC 3.58 is set, NTSC 4.43 will be automatically set at the respective values.	Adjustment of TINT II	Signal generator Oscilloscope Remote control unit	TP-47R/G TP-E (↔) [CRT SOCKET PWB]	6. TINT	[Method of adjustment using measuring instrument]
NTSC 3.58 TINT	<ol style="list-style-type: none"> 1. Receive a NTSC 3.58 full field colour bar signal (75% white). 2. Select 2. V/C from SERVICE MENU. 3. Select 6. TINT with the MENU ▼/▲ key. 4. Set the initial setting value of NTSC 3.58 with the MENU - or + key. 5. Connect the oscilloscope between TP-47R/G and TP-E. 6. Adjust NTSC 3.58 TINT to bring the value of (B) in the illustration to +5V (W&Cy). 					
NTSC 4.43 TINT	When NTSC 3.58 is set, NTSC 4.43 will be automatically set at the respective values.					

Item	Measuring instrument	Test point	Adjustment part	Description
Adjustment of SECAM BLACK OFFSET	Remote control unit Signal generator		7.SECAM BL ADJUST	<ol style="list-style-type: none"> 1. Receive a SECAM full field colour bar signal. 2. Select 2. V/C from SERVICE MENU. 3. Select 7. SECAM BL ADJUST with ▼/▲MENU key. 4. Set the initial setting value with the - or + MENU key. 5. Switch the ①key (colour OFF) and ②key (colour ON) on the remote control and make sure that there is no colour on the black and white screen. 6. If the black and white screen is not best with the initial setting value, make fine adjustment until you get the best black and white screen. 7. Press the DISPLAY key twice to return to the normal screen.
KEY ASSIGNMENT OF REMOTE CONTROL UNIT				

DEFLECTION CIRCUIT ADJUSTMENT

- There are 2 modes of adjustment (setting value) ----- 50Hz mode and 60Hz mode ----- depending upon the kind of signals (vertical frequency 50Hz / 60Hz).
- When adjusted in 50Hz mode, 60Hz mode will be automatically set.

The setting (adjustment) using the REMOTE CONTROL UNIT is made on the basis of the initial setting values. The setting values which adjust the screen to the optimum condition can be different from the initial setting values.

Setting item	Initial setting value	
	50Hz MODE	60Hz MODE
1. VER. POSITION	-2	-3
2. HOR. POSITION	+1	+4
3. VER. HEIGHT	-40	+0
4. VER. LINEARITY	+13	-3
5. VER. SCURVE	-32	+0
6. HOR. VCO ADJUST(Do not adjust)	+0	+0

Item	Measuring instrument	Test point	Adjustment part	Description
Adjustment of V.HEIGHT &V. POSITION	Signal generator Remote control unit		1. VER. POSITION 3. VER. HEIGHT	<p>[Vertical frequency: 50Hz mode]</p> <ol style="list-style-type: none"> 1. Receive a circle pattern signal 2. Select 3. DEF. from SERVICE MENU. 3. Select 1. VER. POSITION with the MENU ▼/▲ key. 4. Set the initial setting value with the MENU - / + key. 5. Adjust 1. VER. POSITION to make $V=V''$ as shown in Fig.1, with the MENU - / + key. 6. Receive a cross-hatch signal. 7. Select 3. V. HEIGHT with the MENU ▼/▲ key. 8. Set the initial setting value with the MENU - / + key. 9. As shown in Fig.2, adjust 3. VER. HEIGHT and make the vertical screen size 92% of the picture size with the MENU - / + keys of remote control unit.

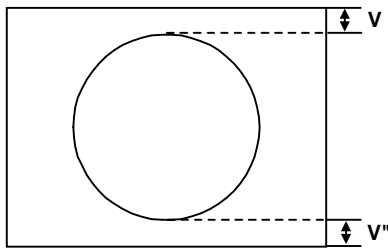

Fig.1

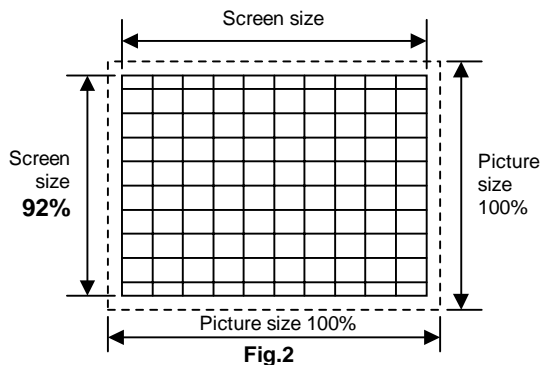

Fig.2

Item	Measuring instrument	Test point	Adjustment part	Description
<p>Adjustment of HOR. POSITION</p>	<p>Signal generator Remote control unit</p>		<p>2. HOR. POSITION</p>	<p>10. Receive a circle pattern signal. 11. Select 2. HOR. POSITION with the MENU ▼/▲ key. 12. Set the initial setting value of 2. HOR. POSITION with the MENU - / + key. 13. Adjust 2. HOR. POSITION to make $H=H''$ as shown in Fig.3 with the MENU - / + key.</p>
<p style="text-align: center;">Fig.3</p>				
<p>Adjustment of VER. LIN. & VER. SCURVE</p>	<p>Signal generator Remote control unit</p>		<p>4. VER. LINEARITY 5. VER. SCURVE</p>	<p>● When the vertical linearity has been deteriorated remarkably, perform the following steps.</p> <p>14. Receive a cross-hatch signal. 15. Select 4. VER. LINEARITY with the MENU ▼/▲ key. 16. Set the initial setting value of 4. VER. LINEARITY with the MENU - / + key. 17. Select 5. VER. SCURVE with the MENU ▼/▲ key. 18. Set the initial setting value of 5. VER. SCURVE with the MENU - / + key. 19. Adjust 4. VER. LINEARITY and 5. VER. SCURVE so that the spaces of each line as shown in Fig.4 on TOP, CENTER and BOTTOM become uniform.</p> <hr/> <p>20. Make sure that the adjustment is properly done on the screen of 60Hz mode.</p> <p>[NOTE]</p> <ul style="list-style-type: none"> ● Adjust to make both 50Hz & 60Hz are the same v. size and fine straight line. ● When adjust again, adjust 50Hz mode first. ● When adjust in 60Hz mode, only 60Hz mode is adjust.
<p style="text-align: center;">Fig.4</p>				

VSM PRESET ADJUSTMENT

Item	Measuring instrument	Test point	Adjustment part	Description																											
<p>Setting of VSM PRESET</p> <div data-bbox="272 663 639 936" style="border: 1px solid black; padding: 5px; margin: 10px 0;"> <p style="text-align: center;">BRIGHT</p> <p> </p> <p> :SELECT - / + : OPERATE DISP : EXIT </p> </div>	<p>Remote control unit</p>		<p>TINT COLOUR BRIGHT CONT. SHARP</p>	<ol style="list-style-type: none"> 1. Select 4. VSM PRESET from the SERVICE MENU. 2. Select BRIGHT with the PICTURE MODE key. 3. Adjust the MENU ▼/▲ and MENU - or + key to bring the set values of TINT ~ SHARP to the values shown in the table. 4. Respectively select the VSM PRESET mode for STANDARD and SOFT, and make similar adjustment as in 3 above. <div data-bbox="572 1079 1374 1503" style="border: 1px solid black; margin: 10px auto; width: 80%; text-align: center;"> <table border="1" style="width: 100%; border-collapse: collapse;"> <thead> <tr> <th rowspan="2" style="text-align: left;">VSM Setting item</th> <th colspan="3">SETTING VALUE</th> </tr> <tr> <th>BRIGHT</th> <th>STANDARD</th> <th>SOFT</th> </tr> </thead> <tbody> <tr> <td>TINT</td> <td>15</td> <td>←</td> <td>←</td> </tr> <tr> <td>COLOUR</td> <td>15</td> <td>←</td> <td>←</td> </tr> <tr> <td>BRIGHT</td> <td>15</td> <td>←</td> <td>←</td> </tr> <tr> <td>CONT.</td> <td>30</td> <td>15</td> <td>11</td> </tr> <tr> <td>SHARP</td> <td>15</td> <td>←</td> <td>12</td> </tr> </tbody> </table> <p>SETTING VALUE OF VSM PRESET</p> </div>	VSM Setting item	SETTING VALUE			BRIGHT	STANDARD	SOFT	TINT	15	←	←	COLOUR	15	←	←	BRIGHT	15	←	←	CONT.	30	15	11	SHARP	15	←	12
VSM Setting item	SETTING VALUE																														
	BRIGHT	STANDARD	SOFT																												
TINT	15	←	←																												
COLOUR	15	←	←																												
BRIGHT	15	←	←																												
CONT.	30	15	11																												
SHARP	15	←	12																												

PRESET ADJUSTMENT (Do not adjust)

- The items in the following table, it is no requirement for adjustment.
- If values had changed by the miss operation, set the initial setting values in the following table.

Setting item		Initial setting value			
		PAL	SECAM	NTSC 3.58	NTSC 4.43
1. C-TRAP FIX		0	←	←	←
2. SHARP PEAK		0	←	←	←
3. ABL		1	←	←	←
4. GAMMA		0	←	←	←
5. Y. DELAY TIME	TV	0	2	←	3
	VIDEO	0	2	0	2
6. BLACK EXP START		3	←	←	←
7. C-BPF	TV	1	←	0	←
	VIDEO	1	←	←	←
8. CW / SCP		0	←	←	←
9. VIF DET LEVEL		+0	←	←	←
11. IF AGC MIN		0	←	←	←
12. VIF AGC		0	←	←	←
13. VIF PMOD		0	←	←	←
19. VNR		15	←	←	←
20. RGB LIM		1	←	←	←
21. RGB LIMIT LEVEL		2	←	←	←
23. TEXT H. POSITION		-3	←	←	←
24. READ DATA		—	—	—	—
Setting item		B/G	I	D/K	M
10. SIF DET LEVEL		+0	←	←	←
14. SIF BPF BW ADJUST		+0	←	←	←
15. SIF TRAP FO ADJUST		+0	←	←	←
16. SIF TRAP FO ADJUST 2		+0	←	←	←
17. SIF -TRAP		0	←	←	←
18. SIF -BPF		0	←	←	1
22. SIF SW		1	←	←	0

PURITY / CONVERGENCE ADJUSTMENT

PURITY ADJUSTMENT

1. Demagnetize CRT with the demagnetizer.
2. Loosen the retainer screw of the deflection yoke.
3. Remove the wedges.
4. Input a green raster signal from the signal generator, and turn the screen to green raster.
5. Move the deflection yoke backward.
6. Bring the long lug of the purity magnets on the short lug and position them horizontally. (Fig.2)
7. Adjust the gap between two lugs so that the GREEN RASTER will come into the center of the screen. (Fig.3)
8. Move the deflection yoke forward, and fix the position of the deflection yoke so that the whole screen will become green.
9. Insert the wedge to the top side of the deflection yoke so that it will not move.
10. Input a crosshatch signal.
11. Verify that the screen is horizontal.
12. Input red and blue raster signals, and make sure that purity is properly adjusted.

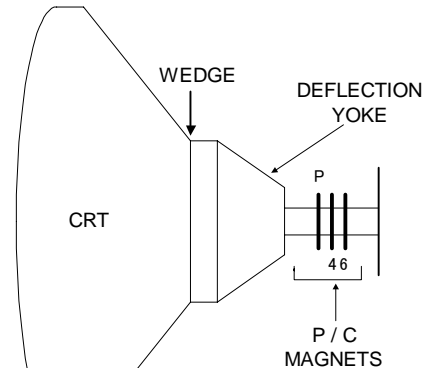

• P/C MAGNETS

P : PURITY MAGNET
 4 : 4 POLES (convergence magnets)
 6 : 6 POLES (convergence magnets)

Fig.1

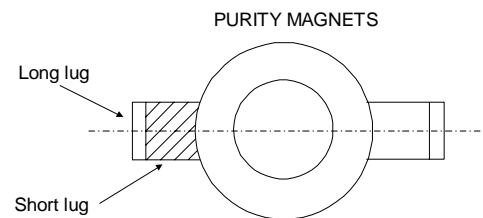

Bring the long lug over the short lug and position them horizontally.

Fig.2

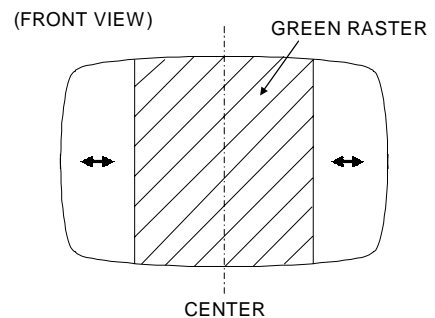

Fig.3

STATIC CONVERGENCE ADJUSTMENT

1. Input a crosshatch signal.
2. Using 4-pole convergence magnets, overlap the red and blue lines in the center of the screen (Fig.1) and turn them to magenta (red/blue).
3. Using 6-pole convergence magnets, overlap the magenta (red/blue) and green lines in the center of the screen and turn them to white.
4. Repeat 2 and 3 above, and make best convergence.

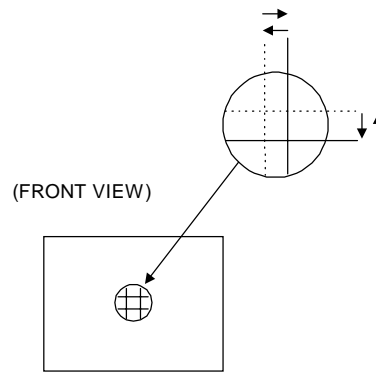

Fig.1

DYNAMIC CONVERGENCE ADJUSTMENT

1. Move the deflection yoke up and down and overlap the lines in the periphery. (Fig. 2)
2. Move the deflection yoke left to right and overlap the lines in the periphery. (Fig. 3)
3. Repeat 1 and 2 above, and make best convergence.

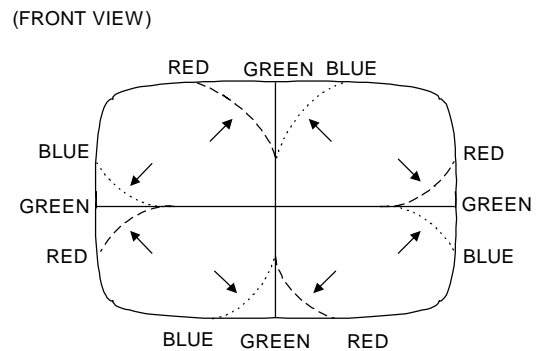

Fig.2

- After adjustment, fix the wedge at the original position. Fasten the retainer screw of the deflection yoke. Fix the 6 magnets with glue.

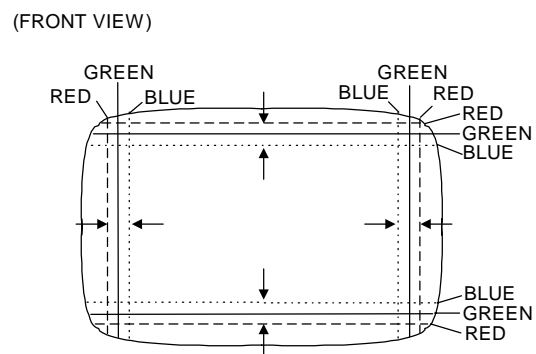

Fig.3

SELF CHECK FUNCTIONS

1. Outline

This model has self check functions given below. When an abnormality has been detected, the SUB POWER is turned OFF and the LED flashes to inform of the failure. An abnormality is detected by the signal input state of the control line connected to the microcomputer.

2. Self check items

Check item	Details of detection	Method of detection	State of abnormality
Over-current protection	An over-current on the B1 line is detected.	The main microcomputer detects the possible abnormality at 20-msecond intervals and judges the results in every 24 time. Of the 24 times, if NG is detected more than 13 times, it is judged that there is an abnormality	When an abnormality has been detected, the SUB-POWER is turned off. While the SUB-POWER is being turned off, the power key of the remote controller is not operational until the power plug is taken out and put in again.
CRT NECK protection	Operation of CRT NECK protection circuit.	DITTO	DITTO

3. Self check indicating function

When an abnormality has been detected at about 3seconds after the power is turned on, the SUB POWER is turned off immediately and the ON TIMER LED flashes.

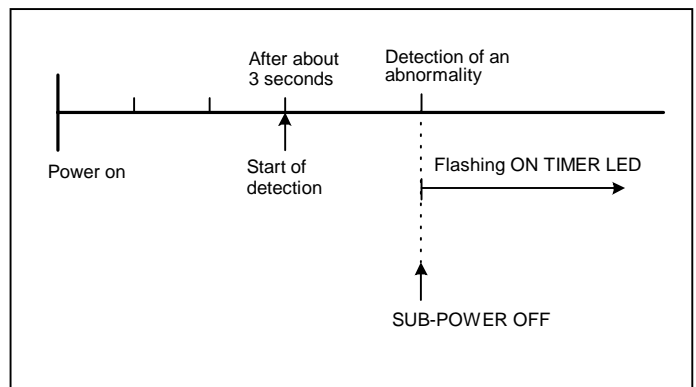

[Indication by ON TIMER LED]

Item	LED flashing intervals
Over-current protection and CRT NECK protection	At 0.24-second intervals

REPLACEMENT OF CHIP COMPONENT

■ CAUTIONS

1. Avoid heating for more than 3 seconds.
2. Do not rub the electrodes and the resist parts of the pattern.
3. When removing a chip part, melt the solder adequately.
4. Do not reuse a chip part after removing it.

■ SOLDERING IRON

1. Use a high insulation soldering iron with a thin pointed end of it.
2. A 30w soldering iron is recommended for easily removing parts.

■ REPLACEMENT STEPS

1. How to remove Chip parts

◆ Resistors, capacitors, etc.

- (1) As shown in the figure, push the part with tweezers and alternately melt the solder at each end.

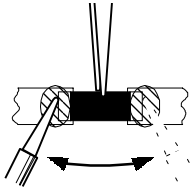

- (2) Shift with tweezers and remove the chip part.

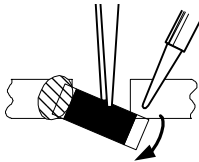

◆ Transistors, diodes, variable resistors, etc.

- (1) Apply extra solder to each lead.

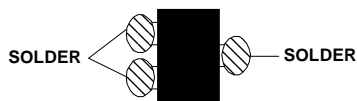

- (2) As shown in the figure, push the part with tweezers and alternately melt the solder at each lead. Shift and remove the chip part.

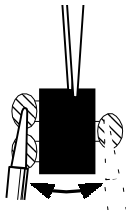

Note : After removing the part, remove remaining solder from the pattern.

2. How to install Chip parts

◆ Resistors, capacitors, etc.

- (1) Apply solder to the pattern as indicated in the figure.

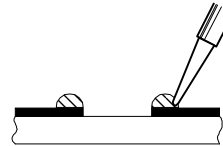

- (2) Grasp the chip part with tweezers and place it on the solder. Then heat and melt the solder at both ends of the chip part.

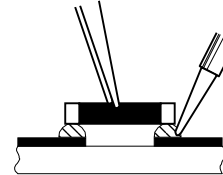

◆ Transistors, diodes, variable resistors, etc.

- (1) Apply solder to the pattern as indicated in the figure.
- (2) Grasp the chip part with tweezers and place it on the solder.
- (3) First solder lead **A** as indicated in the figure.

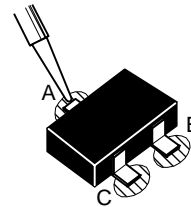

- (4) Then solder leads **B** and **C**.

